

## Process Control for Plant Operators Course

**Training Date** : 08<sup>th</sup> – 12<sup>th</sup> April 2012

**Training Time:** 0730 – 1430 hours

**Training Venue:** Holiday Villa Hotel, Doha, Qatar

**Training Fee:** USD3,500 per participant

### COURSE OBJECTIVES

The course is designed to give participants with a working knowledge on concepts of plant control. Common types of control equipment's including their working principle and tuning techniques will be taught. The participants will be exposed on how to control the process using process simulator. The format is to comprise of short lectures and extensive practical exercise using process simulator, they will learn about PID single loop and multiple loops and their application.

### WHO SHOULD ATTEND?

This Intensive five-day instructional program covering the educational needs of Instrumentation and Control Engineers & Technicians, Engineers with no instrumentation background, Plant Operators, Operation Engineers, Process and Utility Supervisors, and Technical Supervisory personnel involved in Industrial Process Measurement and Control. No specific prerequisite training or experience required for registration

### TRAINING OUTCOMES?

At the end of the course, the participants should be able to:

- ⊕ Recognize the different types of PID modes.
- ⊕ Explain the meaning of the terms used in control technology
- ⊕ Understand the working principle of the pneumatic and electronic controller
- ⊕ Explain process characteristics.
- ⊕ Explain controller characteristics.
- ⊕ Tune process control loop.
- ⊕ Identifies various control loops, such as; single loop, cascade loop, split range, selectors , ratio and Basic feedforward.
- ⊕ Explain and applied enhance control loops and tune their loops.
- ⊕ Recognise feedback and feed forward and able to apply a feedforward controller.
- ⊕ Understand Advanced Process Control

### SELECTED CUSTOMERS



## COURSE PROGRAM

- ⊕ Overview the course and definition of process control
- ⊕ Terminology's
- ⊕ Process Characters;
  - ⊕ Static / Dynamic
  - ⊕ Self Regulating / Non self regulating
  - ⊕ Reverse acting / Direct acting
- ⊕ Control Loop Characters;
  - ⊕ Level
  - ⊕ Temperature
  - ⊕ Pressure
  - ⊕ Flow
- ⊕ Feedback and stability
- ⊕ Elements of process control system.
- ⊕ PID control;
  - ⊕ Proportional Controller
  - ⊕ Proportional + Integral Controller
  - ⊕ Proportional + Integral + Derivative Controller
- ⊕ Tuning process simulator
  - ⊕ Open loop method
  - ⊕ Closed loop method
- ⊕ Operation of Cascade, selector, ratio, split range control.
- ⊕ Tuning enhance PID control.
- ⊕ Feed forward control and tuning
- ⊕ Advance Process Control
  - ⊕ Smith Predictor
  - ⊕ Internal Model Base Controller
  - ⊕ Model Base Controller
- ⊕ Application of multivariable, such as supervisory control system.

## ABOUT THE COURSE INSTRUCTOR

**Engr. Azahar bin Mat Noor**, graduated with Bachelor of Engineering (Honors) in Electrical Engineering and major in control system from the University of Technology Malaysia.

He is a Registered Professional Engineer (Mechanical) with Board of Engineer, Malaysia and a Member, The Institution of Engineers, Malaysia.

He also holds an Instrumentation and Control System certificate from YEW Mitaka, Tokyo.

He had working experiences with several companies such as the Institute Technology Petroleum Petronas (INSTEP) and Centre for Instructor and Advanced Skill Training (CIAST).

Since the past 20 years in teaching, he had delivered for several courses such as;

- ⊕ Process Design and Process and Instrumentation for process engineer.
- ⊕ Process control technology for Instrument Engineer.
- ⊕ Process control technology and application.
- ⊕ Control valves service and repair.
- ⊕ Instrumentation and measurement Engineering.
- ⊕ Basic Instrumentation and Fundamental of Process Control.

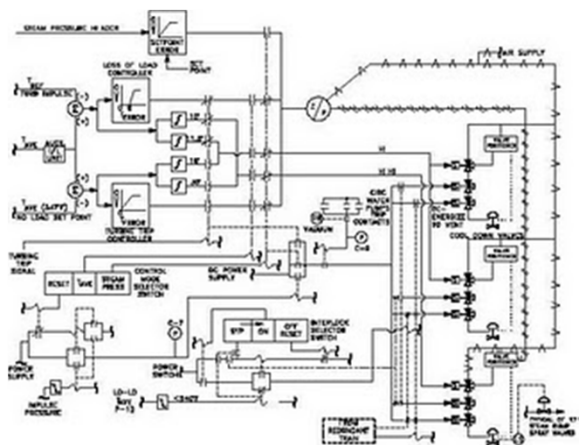

## CFPE TECHNOLOGY SOLUTIONS

Lot 1196, Jalan Mawar 8, Taman Permint Jaya, 21080 Chendering,  
Kuala Terengganu, Terengganu, MALAYSIA.

Tel.: 006.013.208.2143 Fax: 006.09.617.8443

Website: [www.cfpets.com](http://www.cfpets.com) Email: [info@cfpets.com](mailto:info@cfpets.com)

# Registration Form

## Please Send Your Registration To:

<b>Tel:</b>	006.013.208.2143	<b>Fax:</b>	006.09.617.8443	<b>E-mail</b>	info@cfpets.com
-------------	------------------	-------------	-----------------	---------------	-----------------

## Course Details

<b>Course Name:</b>	Process Control for Plant Operators Course	<b>Course Date:</b>	08 – 12 April, 2012
<b>Venue:</b>	Holiday Villa Hotel Doha, State of Qatar	<b>Fee:</b>	USD3,500.00

## Company Information

<b>Organization</b>	
<b>Address</b>	

### HR / Training Manager

### Invoice to be sent to

<b>Name :</b>		
<b>Tel no.:</b>		
<b>Fax no.:</b>		
<b>E-mail :</b>		

## Participant Information

### Participant # 1

### Participant # 2

### Participant # 3

<b>Full Name :</b>			
<b>Job Title :</b>			
<b>Department :</b>			
<b>Telephone No. :</b>			
<b>Mobile No. :</b>			
<b>Fax No. :</b>			
<b>E-mail Address :</b>			

## Please Pay by Telegraphic Transfer to:

<b>Account Name :</b>	CFPE TECHNOLOGY SOLUTIONS
<b>Account No. :</b>	563064120047
<b>Bank Name :</b>	Maybank Islamic Berhad
<b>Branch Name &amp; Address :</b>	Malayan Banking Berhad – CPI, JALAN AIR JERNIH, KUALA TERENGGANU, TERENGGANU, MALAYSIA.
<b>SwiftCode :</b>	MBBEMYKL

## CFPE TECHNOLOGY SOLUTIONS

Lot 1196, Jalan Mawar 8, Taman Permint Jaya, 21080 Chendering, Kuala Terengganu, Terengganu, MALAYSIA.  
Tel.: 006.013.208.2143 Fax: 006.09.617.8443 Website: [www.cfpets.com](http://www.cfpets.com) Email: [info@cfpets.com](mailto:info@cfpets.com)